

南京诺金电气有限公司

Nanjing Nowking Electric Co., Ltd

护线环样本



产品名称：护线环

规格型号：NBK-01

- ◆ MATERIAL: NYLON 66(UL)
- ◆ FLAME CLASS: 94V-2, 94V-0
- ◆ COLOR: BLACK
- ◆ UNIT: mm

用途：用于机壳的电线出线口，保护电线不受机壳刮伤，装配容易。

NBK-01 结构图

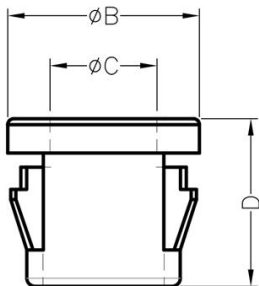

THICKNESS E

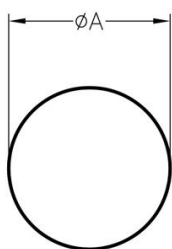
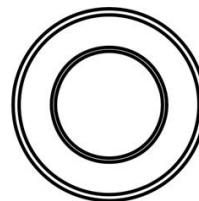

MOUNTING HOLES

PART NO	A	B	C	D	E	PACKAGE
NBK-01	Ø8.0	Ø9.5	Ø5.2	8.2	0.8~1.8	1000

(规格 / 尺寸) 代码说明：

E : 装配板厚

南京诺金电气有限公司

Nanjing Nowking Electric Co., Ltd



产品名称: 护线环

规格型号: NBK-02

- ◆ MATERIAL: NYLON 66(UL)
- ◆ FLAME CLASS: 94V-2, 94V-0
- ◆ COLOR: BLACK
- ◆ UNIT: mm

用途: 用于机壳的电线出线口, 保护电线不受机壳刮伤, 装配容易。

NBK-02 结构图

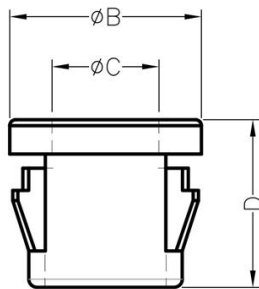

THICKNESS E

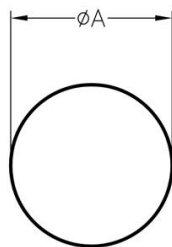
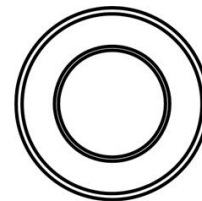

MOUNTING HOLES

PART NO	A	B	C	D	E	PACKAGE
NBK-02	Ø9.5	Ø12.0	Ø6.6	10.3	0.8~3.3	1000

(规格 / 尺寸) 代码说明:

E : 装配板厚



产品名称：护线环

规格型号：NBK-03

- ◆ MATERIAL: NYLON 66(UL)
- ◆ FLAME CLASS: 94V-2, 94V-0
- ◆ COLOR: BLACK
- ◆ UNIT: mm

用途：用于机壳的电线出线口，保护电线不受机壳刮伤，装配容易。

NBK-03 结构图

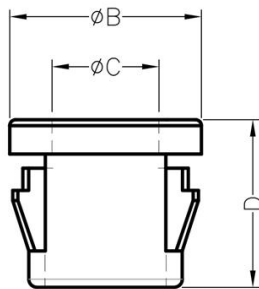

THICKNESS E

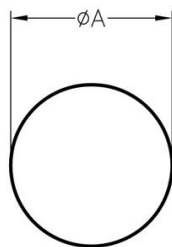
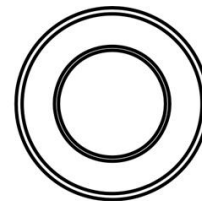

MOUNTING HOLES

PART NO	A	B	C	D	E	PACKAGE
NBK-03	Ø11.1	Ø13.6	Ø8.4	10.3	0.8~3.3	1000

(规格 / 尺寸) 代码说明：

E : 装配板厚



产品名称：护线环

规格型号：NBK-04

- ◆ MATERIAL: NYLON 66(UL)
- ◆ FLAME CLASS: 94V-2, 94V-0
- ◆ COLOR: BLACK
- ◆ UNIT: mm

用途：用于机壳的电线出线口，保护电线不受机壳刮伤，装配容易。

NBK-04 结构图

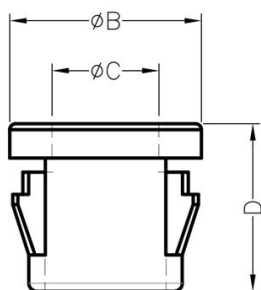

THICKNESS E

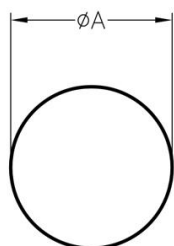
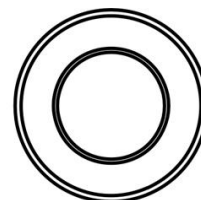

MOUNTING HOLES

PART NO	A	B	C	D	E	PACKAGE
NBK-04	Ø12.7	Ø15.1	Ø9.8	10.3	0.8~3.3	1000

(规格 / 尺寸) 代码说明：

E : 装配板厚



产品名称：护线环

规格型号：NBK-05

- ◆ MATERIAL: NYLON 66(UL)
- ◆ FLAME CLASS: 94V-2, 94V-0
- ◆ COLOR: BLACK
- ◆ UNIT: mm

用途：用于机壳的电线出线口，保护电线不受机壳刮伤，装配容易。

NBK-05 结构图

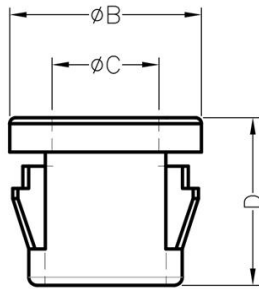

THICKNESS E

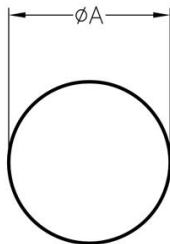
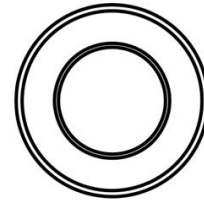

MOUNTING HOLES

PART NO	A	B	C	D	E	PACKAGE
NBK-05	Ø16.0	Ø18.2	Ø12.8	10.3	0.8~3.3	1000

(规格 / 尺寸) 代码说明：

E : 装配板厚

南京诺金电气有限公司

Nanjing Nowking Electric Co., Ltd



产品名称：护线环

规格型号：NBK-06

- ◆ MATERIAL: NYLON 66(UL)
- ◆ FLAME CLASS: 94V-2, 94V-0
- ◆ COLOR: BLACK
- ◆ UNIT: mm

用途：用于机壳的电线出线口，保护电线不受机壳刮伤，装配容易。

NBK-06 结构图

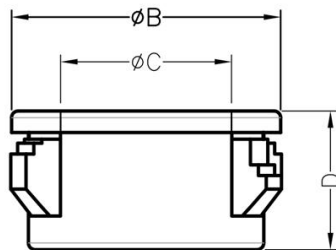

THICKNESS E

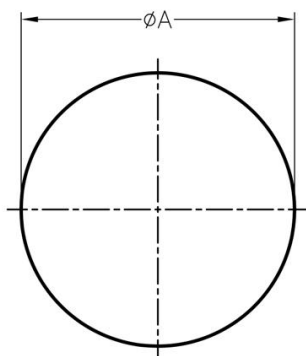
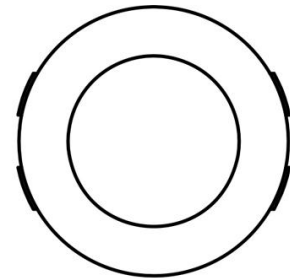

MOUNTING HOLE

PART NO	A	B	C	D	E	PACKAGE
NBK-06	$\phi 19.0$	$\phi 21.5$	$\phi 14.3$	11.3	0.8~3.3	200

(规格 / 尺寸) 代码说明：

E : 装配板厚

南京诺金电气有限公司

Nanjing Nowking Electric Co., Ltd

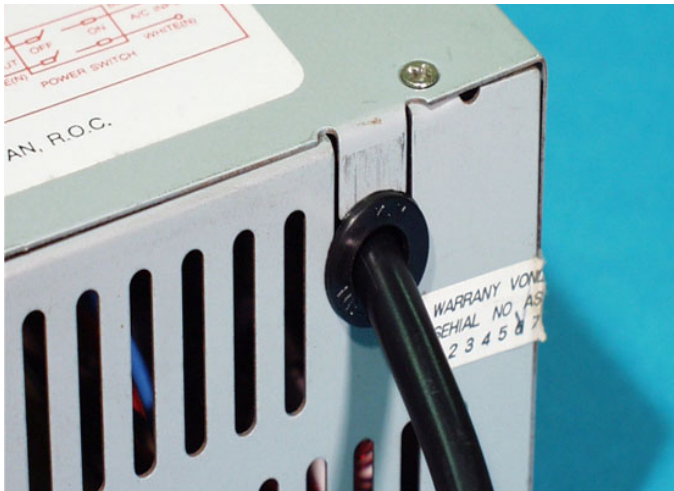

产品名称：护线环

规格型号：NBK-07

- ◆ MATERIAL: NYLON 66(UL)
- ◆ FLAME CLASS: 94V-2, 94V-0
- ◆ COLOR: BLACK
- ◆ UNIT: mm

用途：用于机壳的电线出线口，保护电线不受机壳刮伤，装配容易。

NBK-07 结构图

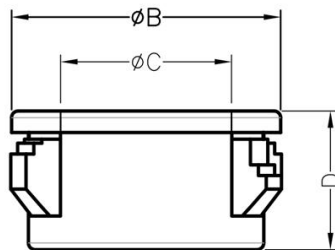

THICKNESS E

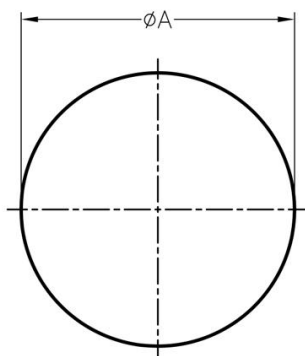
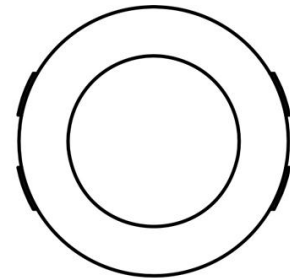

MOUNTING HOLE

PART NO	A	B	C	D	E	PACKAGE
NBK-07	$\phi 17.5$	$\phi 20.0$	$\phi 12.7$	10.3	0.8~3.3	200

(规格 / 尺寸) 代码说明：

E : 装配板厚

南京诺金电气有限公司

Nanjing Nowking Electric Co., Ltd

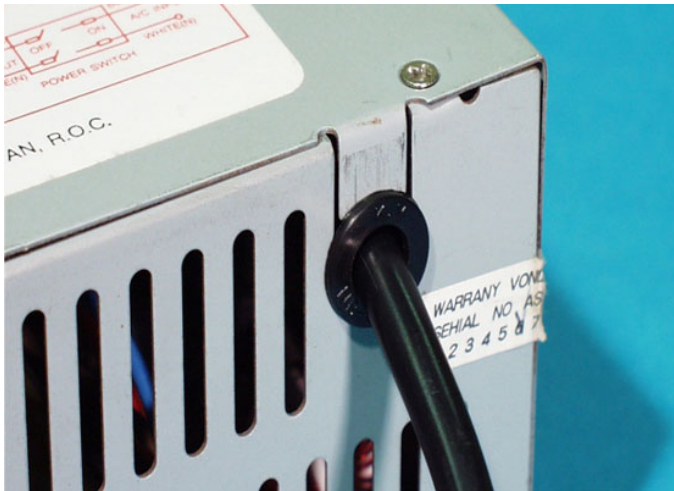

产品名称: 护线环

规格型号: NBK-08

- ◆ MATERIAL: NYLON 66(UL)
- ◆ FLAME CLASS: 94V-2, 94V-0
- ◆ COLOR: BLACK
- ◆ UNIT: mm

用途: 用于机壳的电线出线口, 保护电线不受机壳刮伤, 装配容易。

NBK-08 结构图

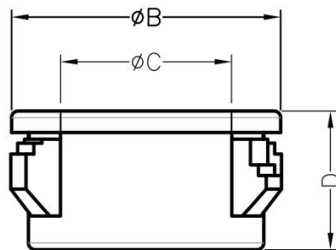

THICKNESS E

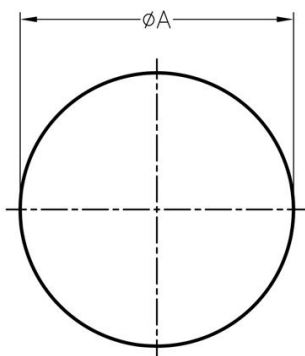
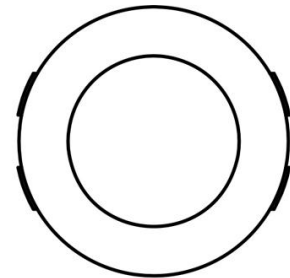

MOUNTING HOLE

PART NO	A	B	C	D	E	PACKAGE
NBK-08	$\phi 22.2$	$\phi 25.1$	$\phi 18.6$	11.2	0.8~3.3	200

(规格 / 尺寸) 代码说明:

E : 装配板厚

南京诺金电气有限公司

Nanjing Nowking Electric Co., Ltd

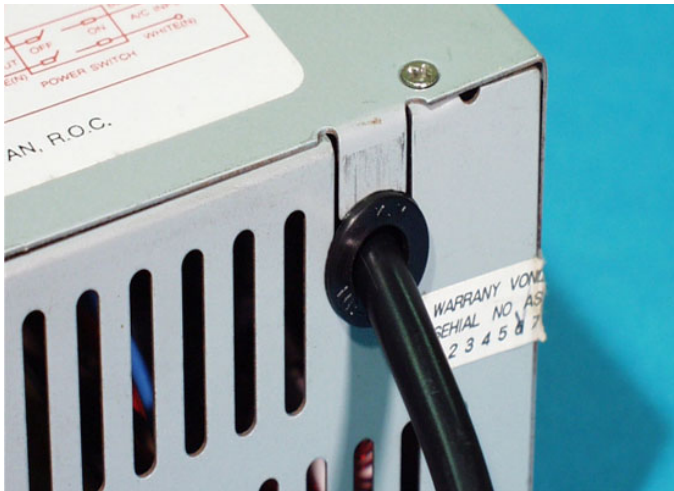

产品名称：护线环

规格型号：NBK-09

- ◆ MATERIAL: NYLON 66(UL)
- ◆ FLAME CLASS: 94V-2, 94V-0
- ◆ COLOR: BLACK
- ◆ UNIT: mm

用途：用于机壳的电线出线口，保护电线不受机壳刮伤，装配容易。

NBK-09 结构图

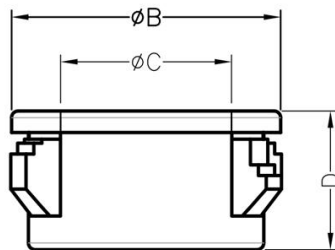

THICKNESS E

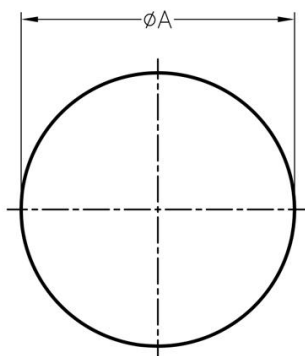
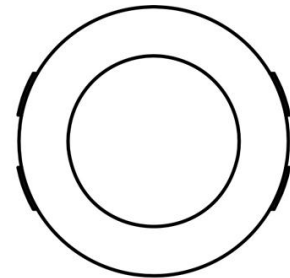

MOUNTING HOLE

PART NO	A	B	C	D	E	PACKAGE
NBK-09	$\phi 22.2$	$\phi 23.8$	$\phi 19.0$	6.3	0.8~1.6	200

(规格 / 尺寸) 代码说明：

E : 装配板厚

南京诺金电气有限公司

Nanjing Nowking Electric Co., Ltd

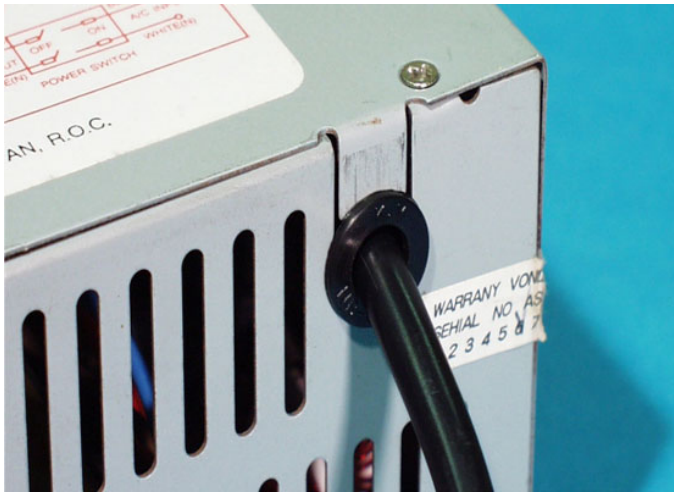

产品名称: 护线环

规格型号: NBK-10

- ◆ MATERIAL: NYLON 66(UL)
- ◆ FLAME CLASS: 94V-2, 94V-0
- ◆ COLOR: BLACK
- ◆ UNIT: mm

用途: 用于机壳的电线出线口, 保护电线不受机壳刮伤, 装配容易。

NBK-10 结构图

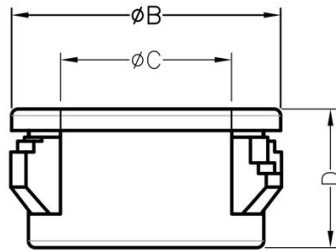

THICKNESS E

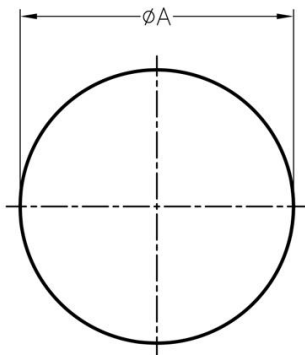
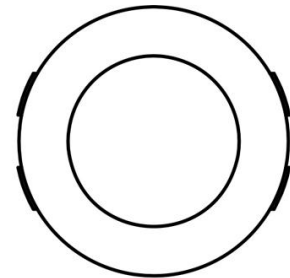

MOUNTING HOLE

PART NO	A	B	C	D	E	PACKAGE
NBK-10	$\phi 25.4$	$\phi 27.8$	$\phi 19.4$	10.8	0.8~3.3	200

(规格 / 尺寸) 代码说明:

E : 装配板厚

南京诺金电气有限公司

Nanjing Nowking Electric Co., Ltd

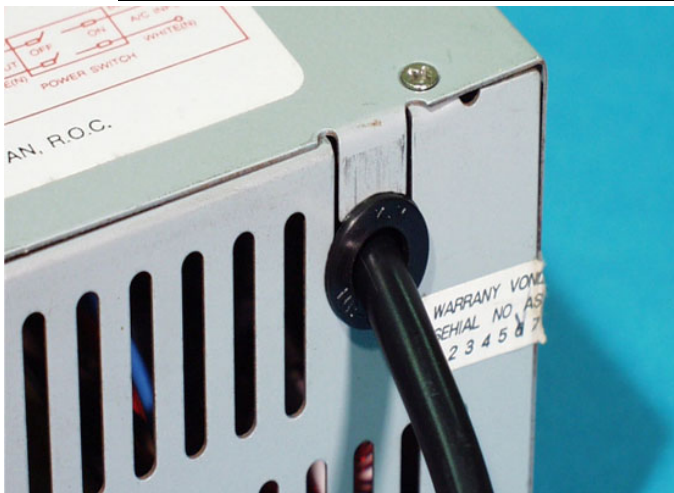

产品名称: 护线环

规格型号: NBK-11

- ◆ MATERIAL: NYLON 66(UL)
- ◆ FLAME CLASS: 94V-2, 94V-0
- ◆ COLOR: BLACK
- ◆ UNIT: mm

用途: 用于机壳的电线出线口, 保护电线不受机壳刮伤, 装配容易。

NBK-11 结构图

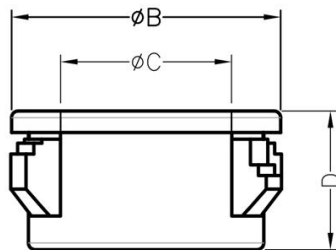

THICKNESS E

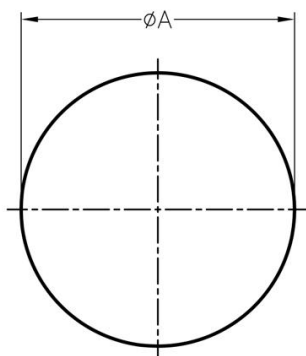
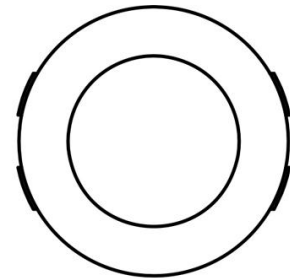

MOUNTING HOLE

PART NO	A	B	C	D	E	PACKAGE
NBK-11	$\phi 28.0$	$\phi 31.5$	$\phi 24.1$	11.3	1.0~3.3	200

(规格 / 尺寸) 代码说明:

E : 装配板厚

南京诺金电气有限公司

Nanjing Nowking Electric Co., Ltd

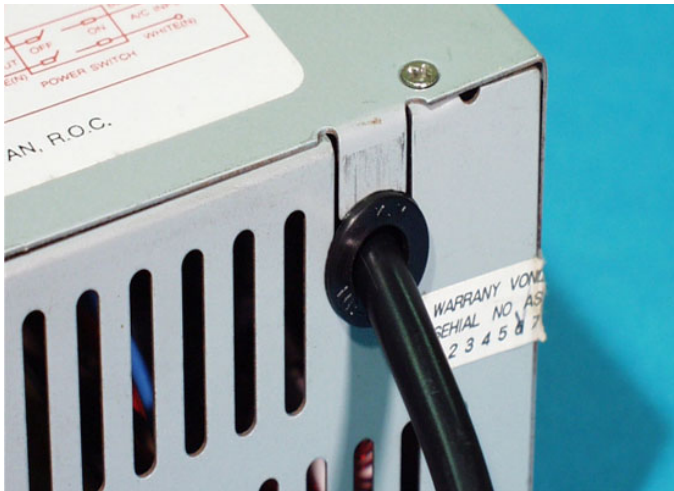

产品名称: 护线环

规格型号: NBK-12

- ◆ MATERIAL: NYLON 66(UL)
- ◆ FLAME CLASS: 94V-2, 94V-0
- ◆ COLOR: BLACK
- ◆ UNIT: mm

用途: 用于机壳的电线出线口, 保护电线不受机壳刮伤, 装配容易。

NBK-12 结构图

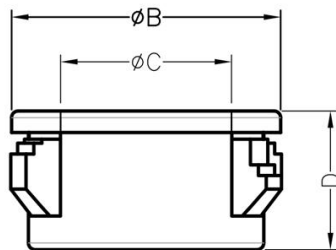

THICKNESS E

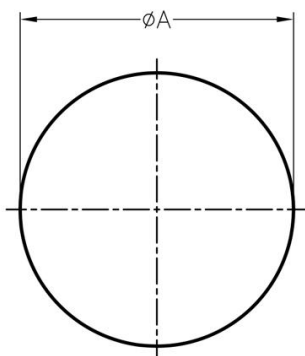
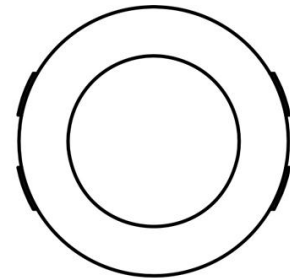

MOUNTING HOLE

PART NO	A	B	C	D	E	PACKAGE
NBK-12	$\phi 30.1$	$\phi 34.0$	$\phi 24.5$	11.7	0.8~3.3	200

(规格 / 尺寸) 代码说明:

E : 装配板厚

南京诺金电气有限公司

Nanjing Nowking Electric Co., Ltd

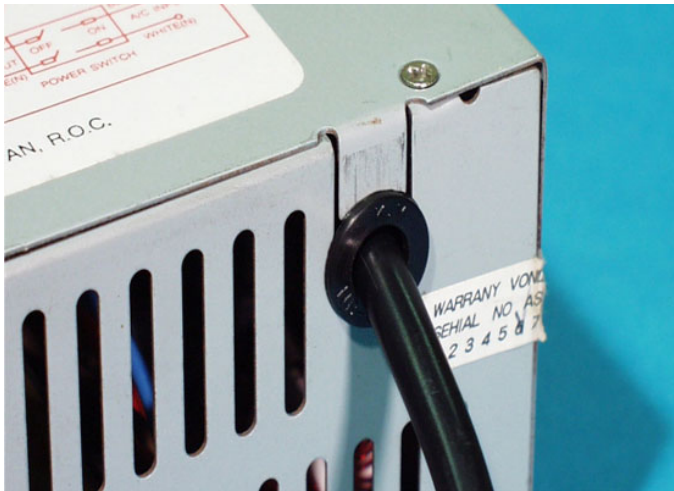

产品名称: 护线环

规格型号: NBK-13

- ◆ MATERIAL: NYLON 66(UL)
- ◆ FLAME CLASS: 94V-2, 94V-0
- ◆ COLOR: BLACK
- ◆ UNIT: mm

用途: 用于机壳的电线出线口, 保护电线不受机壳刮伤, 装配容易。

NBK-13 结构图

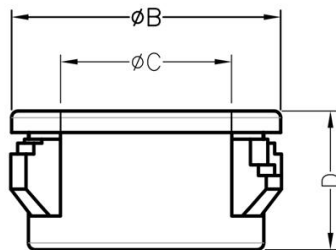

THICKNESS E

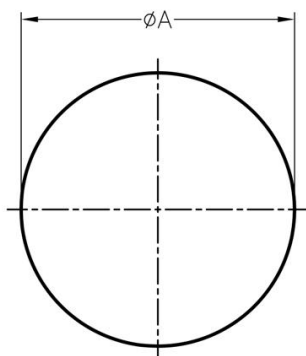
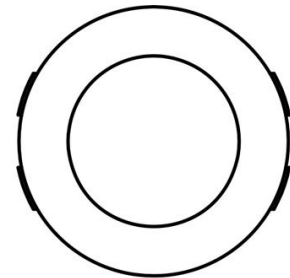

MOUNTING HOLE

PART NO	A	B	C	D	E	PACKAGE
NBK-13	$\phi 35.0$	$\phi 37.8$	$\phi 25.8$	11.3	0.8~3.5	200

(规格 / 尺寸) 代码说明:

E : 装配板厚

南京诺金电气有限公司

Nanjing Nowking Electric Co., Ltd



产品名称: 护线环

规格型号: NBK-14

- ◆ MATERIAL: NYLON 66(UL)
- ◆ FLAME CLASS: 94V-2, 94V-0
- ◆ COLOR: BLACK
- ◆ UNIT: mm

用途: 用于机壳的电线出线口, 保护电线不受机壳刮伤, 装配容易。

NBK-14 结构图

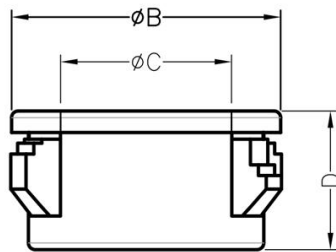

THICKNESS E

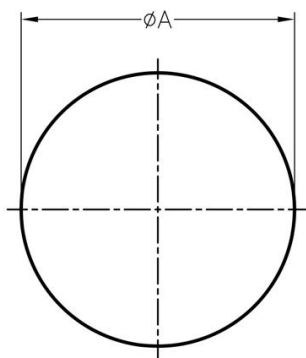
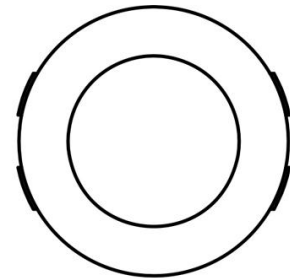

MOUNTING HOLE

PART NO	A	B	C	D	E	PACKAGE
NBK-14	$\phi 35.0$	$\phi 37.8$	$\phi 29.7$	11.3	0.8~3.5	200

(规格 / 尺寸) 代码说明:

E : 装配板厚

南京诺金电气有限公司

Nanjing Nowking Electric Co., Ltd

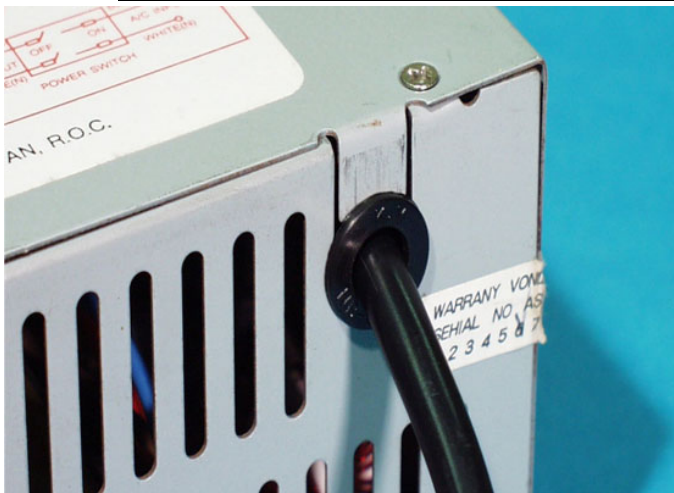

产品名称: 护线环

规格型号: NBK-15

- ◆ MATERIAL: NYLON 66(UL)
- ◆ FLAME CLASS: 94V-2, 94V-0
- ◆ COLOR: BLACK
- ◆ UNIT: mm

用途: 用于机壳的电线出线口, 保护电线不受机壳刮伤, 装配容易。

NBK-15 结构图

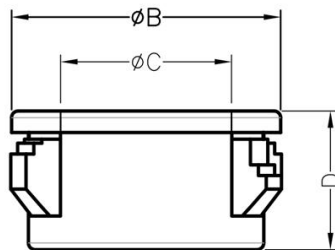

THICKNESS E

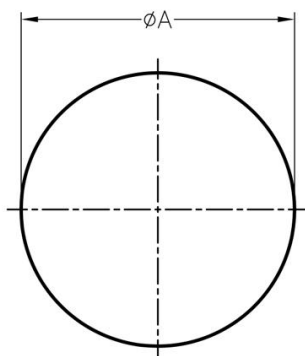
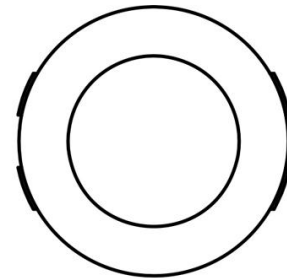

MOUNTING HOLE

PART NO	A	B	C	D	E	PACKAGE
NBK-15	$\phi 34.2$	$\phi 38.0$	$\phi 26.2$	11.5	1.0~3.1	200

(规格 / 尺寸) 代码说明:

E : 装配板厚

南京诺金电气有限公司

Nanjing Nowking Electric Co., Ltd



产品名称: 护线环

规格型号: NBK-16

- ◆ MATERIAL: NYLON 66(UL)
- ◆ FLAME CLASS: 94V-2, 94V-0
- ◆ COLOR: BLACK
- ◆ UNIT: mm

用途: 用于机壳的电线出线口, 保护电线不受机壳刮伤, 装配容易。

NBK-16 结构图

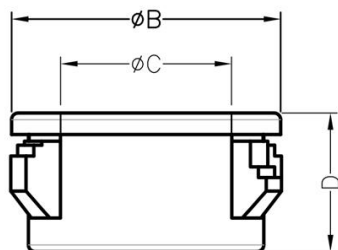

THICKNESS E

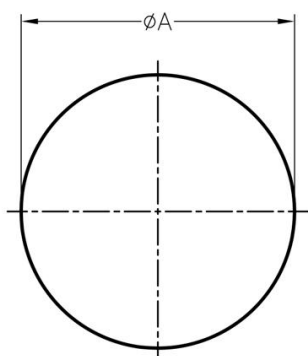
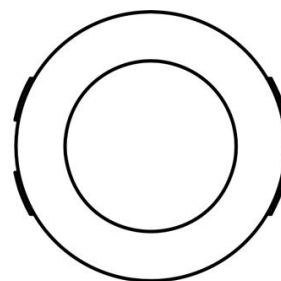

MOUNTING HOLE

PART NO	A	B	C	D	E	PACKAGE
NBK-16	$\phi 34.2$	$\phi 38.0$	$\phi 30.4$	11.5	1.0~3.1	200

(规格 / 尺寸) 代码说明:

E : 装配板厚

南京诺金电气有限公司

Nanjing Nowking Electric Co., Ltd



产品名称：护线环

规格型号：NBK-17

- ◆ MATERIAL: NYLON 66(UL)
- ◆ FLAME CLASS: 94V-2, 94V-0
- ◆ COLOR: BLACK
- ◆ UNIT: mm

用途：用于机壳的电线出线口，保护电线不受机壳刮伤，装配容易。

NBK-17 结构图

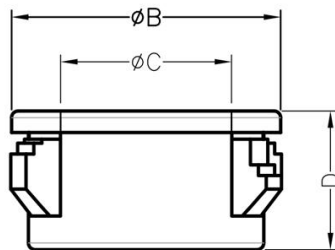

THICKNESS E

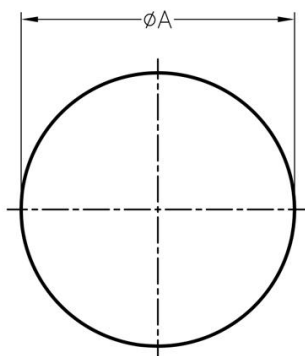
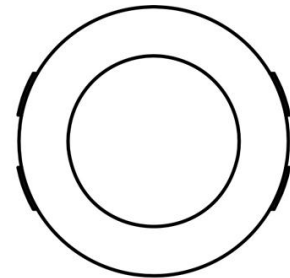

MOUNTING HOLE

PART NO	A	B	C	D	E	PACKAGE
NBK-17	$\phi 38.0$	$\phi 41.2$	$\phi 33.3$	11.6	1.0~3.3	200

(规格 / 尺寸) 代码说明：

E : 装配板厚

南京诺金电气有限公司

Nanjing Nowking Electric Co., Ltd



产品名称：护线环

规格型号：NBK-18

- ◆ MATERIAL: NYLON 66(UL)
- ◆ FLAME CLASS: 94V-2, 94V-0
- ◆ COLOR: BLACK
- ◆ UNIT: mm

用途：用于机壳的电线出线口，保护电线不受机壳刮伤，装配容易。

NBK-18 结构图

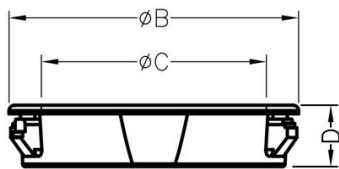

THICKNESS E

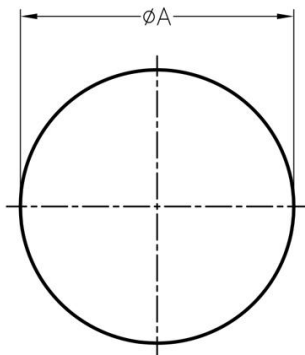
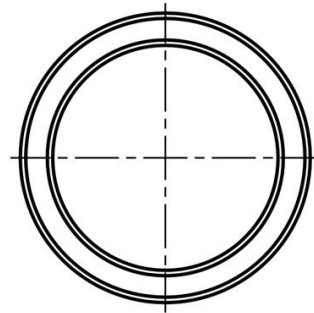

MOUNTING HOLE

PART NO	A	B	C	D	E	PACKAGE
NBK-18	50.8	53.8	41.8	11.4	0.8~3.2	100

(规格 / 尺寸) 代码说明：

E : 装配板厚

南京诺金电气有限公司

Nanjing Nowking Electric Co., Ltd



产品名称：护线环

规格型号：NBK-19

- ◆ MATERIAL: NYLON 66(UL)
- ◆ FLAME CLASS: 94V-2, 94V-0
- ◆ COLOR: BLACK
- ◆ UNIT: mm

用途：用于机壳的电线出线口，保护电线不受机壳刮伤，装配容易。

NBK-19 结构图

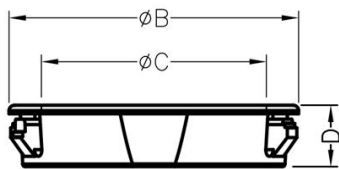

THICKNESS E

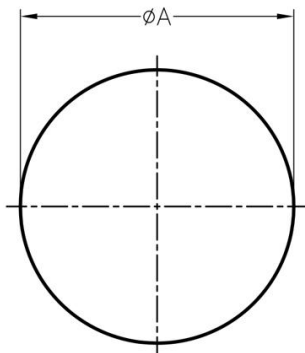
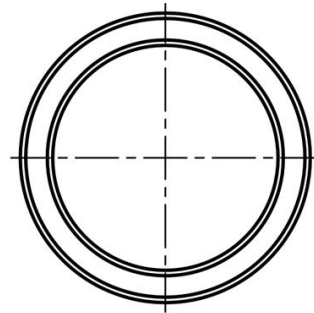

MOUNTING HOLE

PART NO	A	B	C	D	E	PACKAGE
NBK-19	50.8	53.8	44.3	11.4	0.8~3.2	100

(规格 / 尺寸) 代码说明：

E : 装配板厚

南京诺金电气有限公司

Nanjing Nowking Electric Co., Ltd



产品名称：护线环

规格型号：NBK-20

- ◆ MATERIAL: NYLON 66(UL)
- ◆ FLAME CLASS: 94V-2, 94V-0
- ◆ COLOR: BLACK
- ◆ UNIT: mm

用途：用于机壳的电线出线口，保护电线不受机壳刮伤，装配容易。

NBK-20 结构图

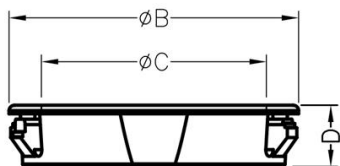

THICKNESS E

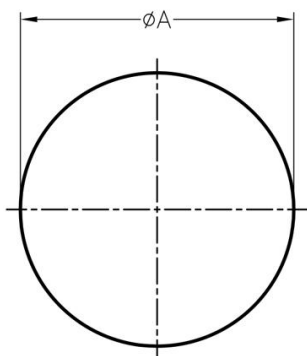
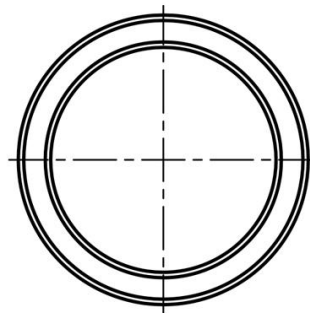

MOUNTING HOLE

PART NO	A	B	C	D	E	PACKAGE
NBK-20	57.1	63.0	47.3	18.1	6.35	100

(规格 / 尺寸) 代码说明：

E : 装配板厚

南京诺金电气有限公司

Nanjing Nowking Electric Co., Ltd



产品名称：护线环

规格型号：NBK-21

- ◆ MATERIAL: NYLON 66(UL)
- ◆ FLAME CLASS: 94V-2, 94V-0
- ◆ COLOR: BLACK
- ◆ UNIT: mm

用途：用于机壳的电线出线口，保护电线不受机壳刮伤，装配容易。

NBK-21 结构图

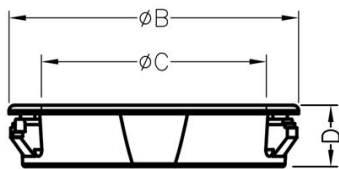

THICKNESS E

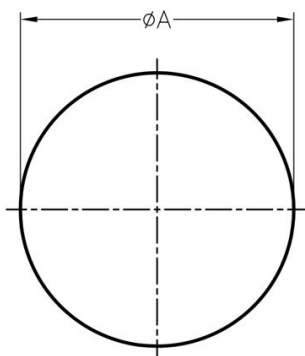
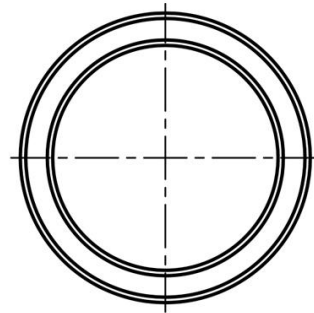

MOUNTING HOLE

PART NO	A	B	C	D	E	PACKAGE
NBK-21	63.5	67.5	50.5	18.1	6.35	100

(规格 / 尺寸) 代码说明：

E : 装配板厚

南京诺金电气有限公司

Nanjing Nowking Electric Co., Ltd



产品名称：护线环

规格型号：NBK-22

- ◆ MATERIAL: NYLON 66(UL)
- ◆ FLAME CLASS: 94V-2, 94V-0
- ◆ COLOR: BLACK
- ◆ UNIT: mm

用途：用于机壳的电线出线口，保护电线不受机壳刮伤，装配容易。

NBK-22 结构图

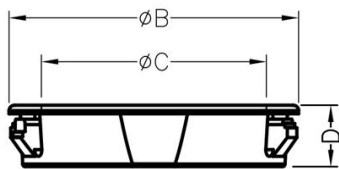

THICKNESS E

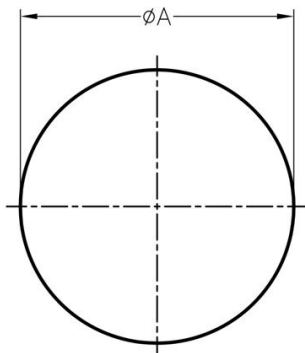
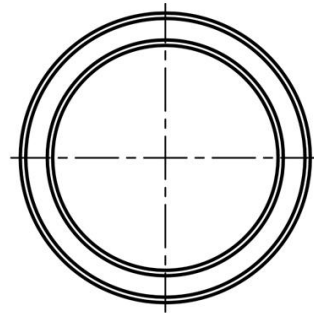

MOUNTING HOLE

PART NO	A	B	C	D	E	PACKAGE
NBK-22	63.5	67.5	55.5	18.1	6.35	100

(规格 / 尺寸) 代码说明：

E : 装配板厚



产品名称：护线环

规格型号：NBK-23

- ◆ MATERIAL: NYLON 66(UL)
- ◆ FLAME CLASS: 94V-2, 94V-0
- ◆ COLOR: BLACK
- ◆ UNIT: mm

用途：用于机壳的电线出线口，保护电线不受机壳刮伤，装配容易。

NBK-23 结构图

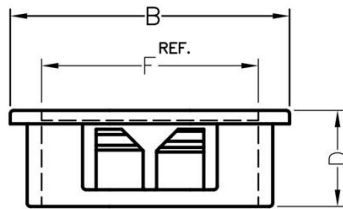

THICKNESS E

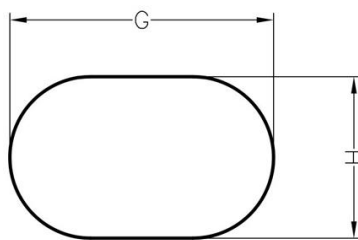
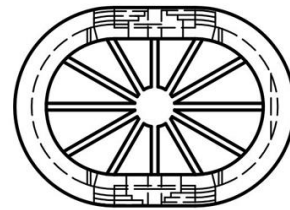

MOUNTING HOLE

PART NO	B	D	E	F	G	H	PACKAGE
NBK-23	34.0	6.5	0.8~1.5	26.7	30.5	25.0	1000

(规格 / 尺寸) 代码说明：

E : 装配板厚

南京诺金电气有限公司

Nanjing Nowking Electric Co., Ltd



产品名称：护线环

规格型号：NBK-24

- ◆ MATERIAL: NYLON 66(UL)
- ◆ FLAME CLASS: 94V-2, 94V-0
- ◆ COLOR: BLACK
- ◆ UNIT: mm

用途：用于机壳的电线出线口，保护电线不受机壳刮伤，装配容易。

NBK-24 结构图

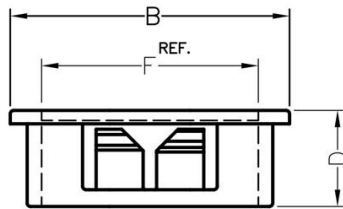

THICKNESS E

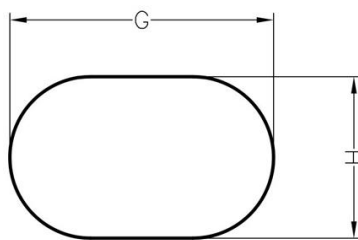
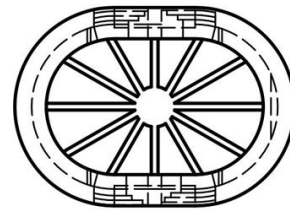

MOUNTING HOLE

PART NO	B	D	E	F	G	H	PACKAGE
NBK-24	41.5	14.3	1.2~3.0	32.2	37.0	25.0	500

(规格 / 尺寸) 代码说明：

E : 装配板厚



产品名称：护线环

规格型号：NBK-25

- ◆ MATERIAL: NYLON 66(UL)
- ◆ FLAME CLASS: 94V-2, 94V-0
- ◆ COLOR: BLACK
- ◆ UNIT: mm

用途：用于机壳的电线出线口，保护电线不受机壳刮伤，装配容易。

NBK-25 结构图

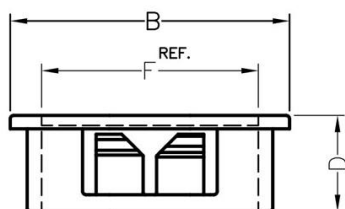

THICKNESS E

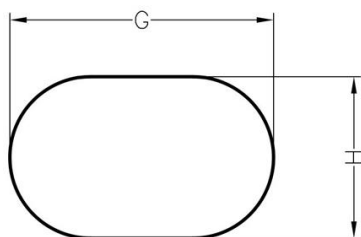
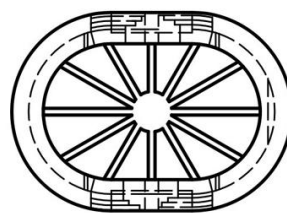

MOUNTING HOLE

PART NO	B	D	E	F	G	H	PACKAGE
NBK-25	54.2	14.3	1.2~3.0	44.9	50.0	30.0	100

(规格 / 尺寸) 代码说明：

E : 装配板厚



产品名称：护线环

规格型号：NBK-26

- ◆ MATERIAL: NYLON 66(UL)
- ◆ FLAME CLASS: 94V-2, 94V-0
- ◆ COLOR: BLACK
- ◆ UNIT: mm

用途：用于机壳的电线出线口，保护电线不受机壳刮伤，装配容易。

NBK-26 结构图

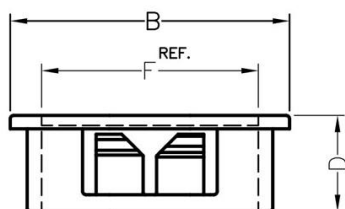

THICKNESS E

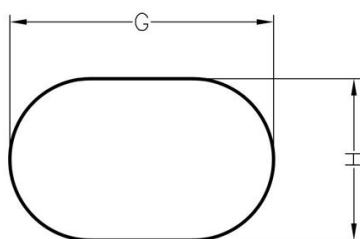
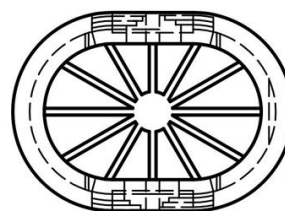

MOUNTING HOLE

PART NO	B	D	E	F	G	H	PACKAGE
NBK-26	54.2	7.5	0.8~1.6	44.9	50.0	30.0	100

(规格 / 尺寸) 代码说明：

E : 装配板厚



产品名称：护线环

规格型号：NBK-27

- ◆ MATERIAL: NYLON 66(UL)
- ◆ FLAME CLASS: 94V-2, 94V-0
- ◆ COLOR: BLACK
- ◆ UNIT: mm

用途：用于机壳的电线出线口，保护电线不受机壳刮伤，装配容易。

NBK-27 结构图

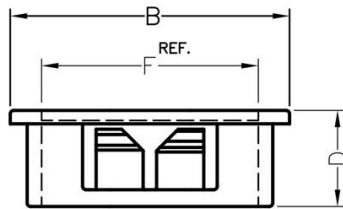

THICKNESS E

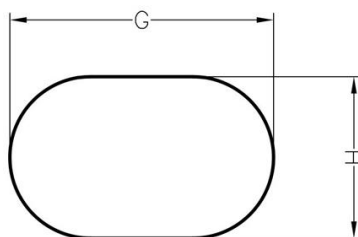
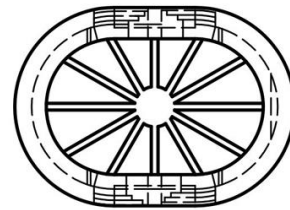

MOUNTING HOLE

PART NO	B	D	E	F	G	H	PACKAGE
NBK-27	84.0	14.3	1.2~3.0	71.4	80.0	54.0	50

(规格 / 尺寸) 代码说明：

E : 装配板厚

南京诺金电气有限公司

Nanjing Nowking Electric Co., Ltd

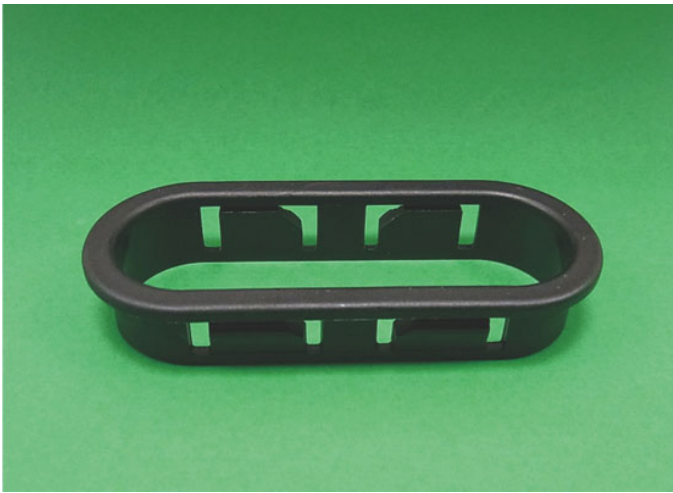

产品名称: 护线环

规格型号: NBK-28

- ◆ MATERIAL: NYLON 66(UL)
- ◆ FLAME CLASS: 94V-2, 94V-0
- ◆ COLOR: BLACK
- ◆ UNIT: mm

用途: 用于机壳的电线出线口, 保护电线不受机壳刮伤, 装配容易。

NBK-28 结构图

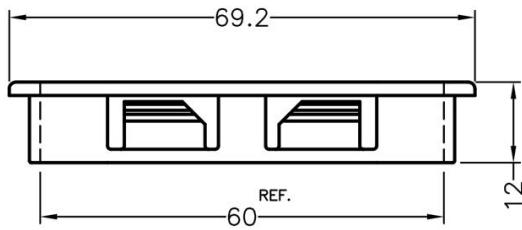

THICKNESS 0.8~2.5

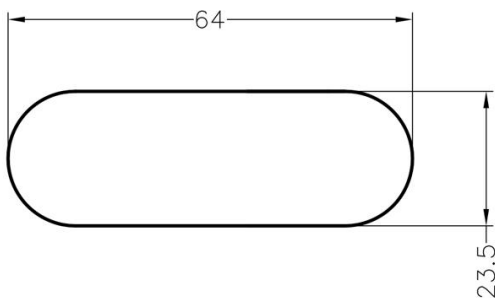
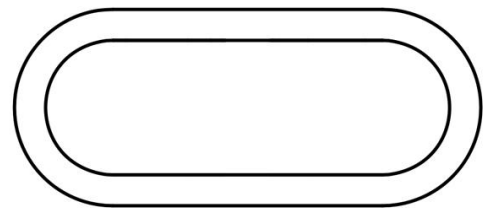

MOUNTING HOLE

PART NO	PACKAGE
NBK-28	50

南京诺金电气有限公司

Nanjing Nowking Electric Co., Ltd

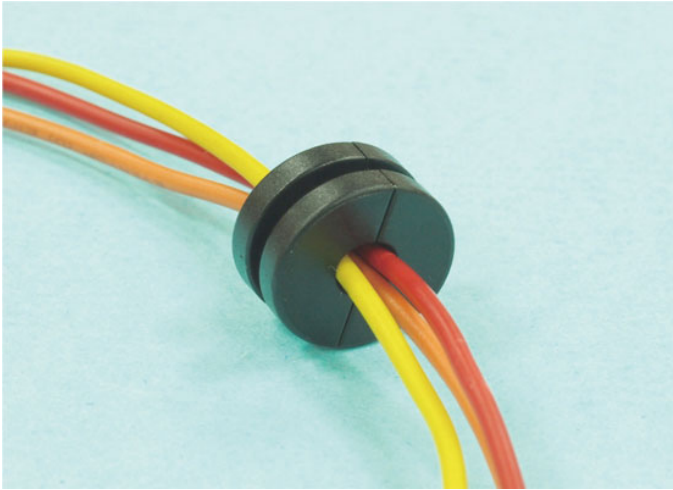

产品名称：护线环

规格型号：NBK-29

- ◆ MATERIAL:PC+ABS(UL)
- ◆ FLAME CLASS:94V-2,94V-0
- ◆ COLOR:BLACK
- ◆ UNIT: mm

用途：用于电线、电缆之固定及保护。

NBK-29 结构图

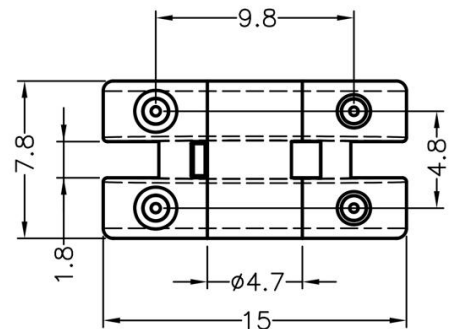
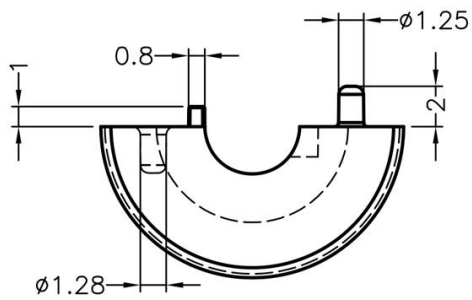

	PART NO	PACKAGE
	NBK-29	1000

南京诺金电气有限公司

Nanjing Nowking Electric Co., Ltd

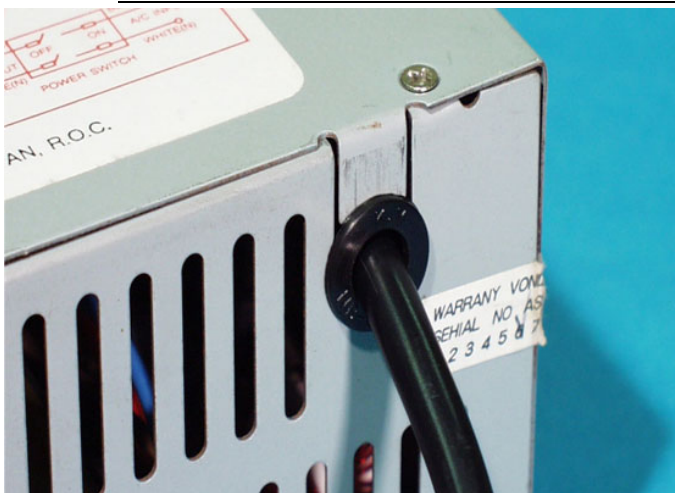

产品名称：护线环

规格型号：NBK-30

- ◆ MATERIAL: NYLON 66(UL)
- ◆ FLAME CLASS: 94V-2, 94V-0
- ◆ COLOR: BLACK
- ◆ UNIT: mm

用途：用于机壳的电线出线口，保护电线不受机壳刮伤，装配容易。

NBK-30 结构图

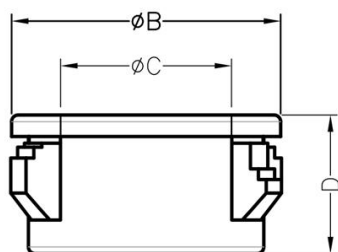

THICKNESS E

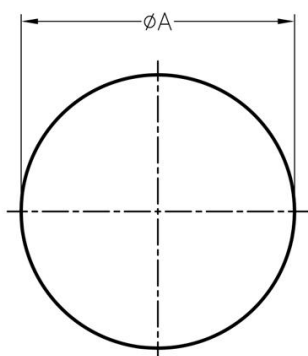
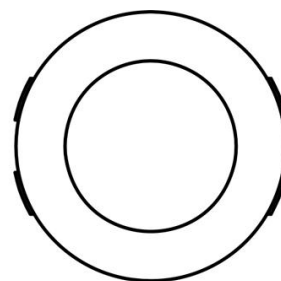

MOUNTING HOLE

PART NO	A	B	C	D	E	PACKAGE
NBK-30	$\phi 10.0$	$\phi 12.1$	$\phi 7.2$	6.6	0.8~1.8	1000

(规格 / 尺寸) 代码说明：

E : 装配板厚

南京诺金电气有限公司

Nanjing Nowking Electric Co., Ltd

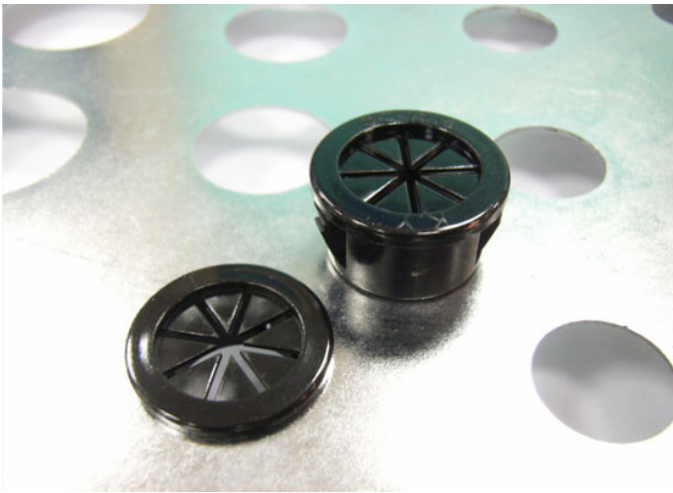

产品名称：护线环

规格型号：NBK-31

- ◆ MATERIAL: NYLON 66(UL)
- ◆ FLAME CLASS: 94V-2, 94V-0
- ◆ COLOR: BLACK
- ◆ UNIT: mm

用途：用于机壳的电线出线口，保护电线不受机壳刮伤，装配容易。

NBK-31 结构图

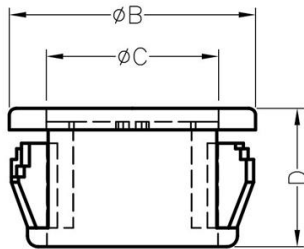

THICKNESS E

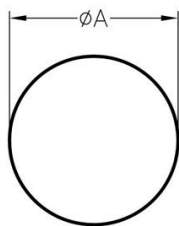
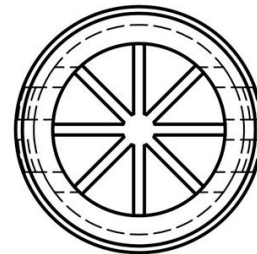

MOUNTING HOLE

PART NO	A	B	C	D	E	PACKAGE
NBK-31	15.9	18.3	12.8	10.3	3.2 MAX	1000

(规格 / 尺寸) 代码说明：

E : 装配板厚

南京诺金电气有限公司

Nanjing Nowking Electric Co., Ltd

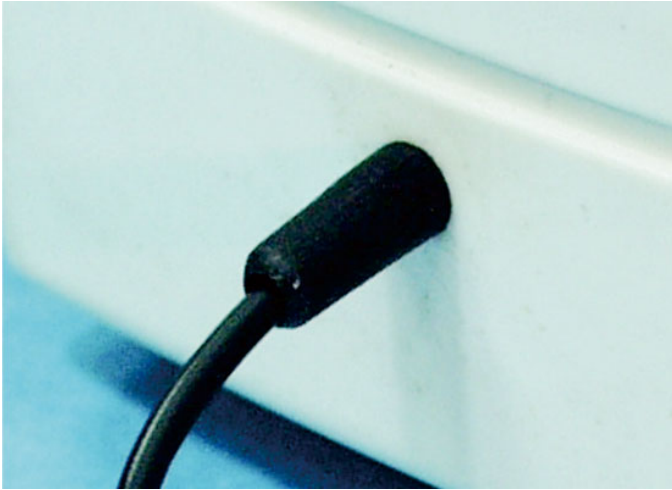

产品名称：护线环

规格型号：NBK-32

◆ MATERIAL:TPE

◆ COLOR:BLACK

◆ UNIT: mm

用途：用于电线、电缆之固定及保护。

NBK-32 结构图

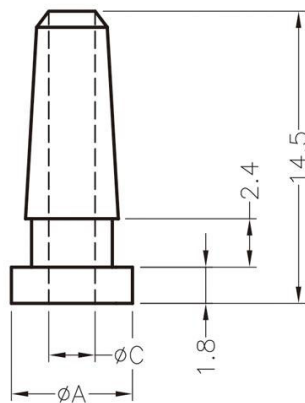

MOUNTING HOLES

PART NO	A	B	C	PACKAGE
NBK-32	6.0	4.0	2.3	1000

南京诺金电气有限公司

Nanjing Nowking Electric Co., Ltd

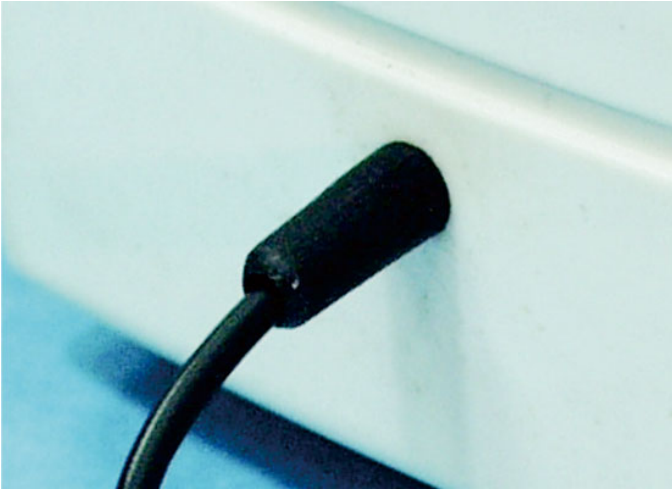

产品名称：护线环

规格型号：NBK-33

◆ MATERIAL:TPE

◆ COLOR:BLACK

◆ UNIT: mm

用途：用于电线、电缆之固定及保护。

NBK-33 结构图

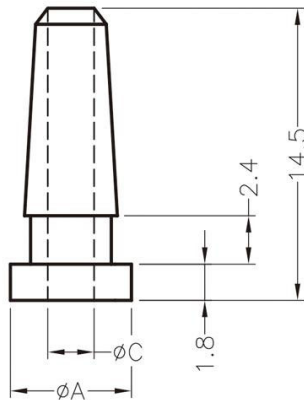

MOUNTING HOLES

PART NO	A	B	C	PACKAGE
NBK-33	7.0	4.8	3.0	1000

南京诺金电气有限公司

Nanjing Nowking Electric Co., Ltd



产品名称：护线环

规格型号：NBK-34

- ◆ MATERIAL: NYLON 66(UL)
- ◆ FLAME CLASS: 94V-2, 94V-0
- ◆ COLOR: BLACK, NATURAL
- ◆ UNIT: mm

用途：用于机壳的电线出线口，保护电线不受机壳刮伤，装配容易。

NBK-34 结构图

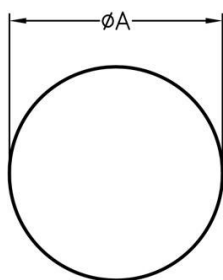
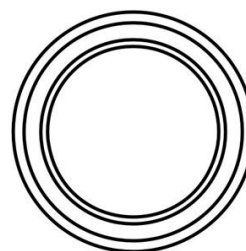
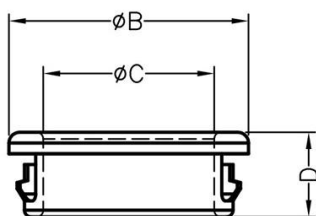

MOUNTING HOLE
THICKNESS: E

PART NO	A	B	C	D	E	PACKAGE
NBK-34	Ø15.8	Ø17.8	Ø12.7	6.3	0.8~1.6	1000

(规格 / 尺寸) 代码说明：

E : 装配板厚

南京诺金电气有限公司

Nanjing Nowking Electric Co., Ltd



产品名称：护线环

规格型号：NBK-35

- ◆ MATERIAL: NYLON 66(UL)
- ◆ FLAME CLASS: 94V-2, 94V-0
- ◆ COLOR: BLACK
- ◆ UNIT: mm

用途：用于机壳的电线出线口，保护电线不受机壳刮伤，装配容易。

内缩为正常现象

所有尺寸量测皆不含进胶口，胶口凸出 0.3mm 之内可使用同等材质

NBK-35 结构图

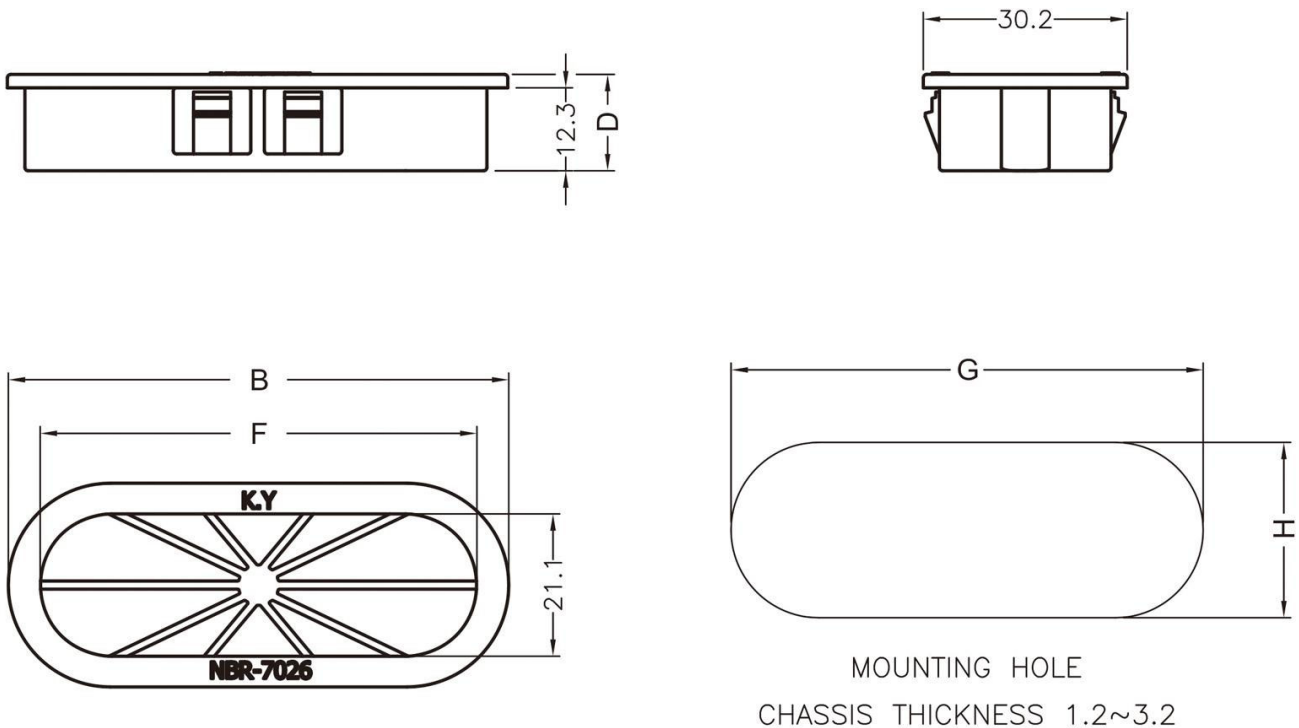

PART NO	B	D	E	F	G	H	PACKAGE
NBK-35	74.2	14.3	1.2~3.2	64.7	70.0	26.0	100

(规格 / 尺寸) 代码说明：

E : 装配板厚

南京诺金电气有限公司

Nanjing Nowking Electric Co., Ltd



产品名称：护线环

规格型号：NBK-36

- ◆ MATERIAL: NYLON 66(UL)
- ◆ FLAME CLASS: 94V-2, 94V-0
- ◆ COLOR: BLACK
- ◆ UNIT: mm

用途：用于机壳的电线出线口，保护电线不受机壳刮伤，装配容易。

内缩为正常现象

所有尺寸量测皆不含进胶口，胶口凸出 0.3mm 之内可使用同等材质

NBK-36 结构图

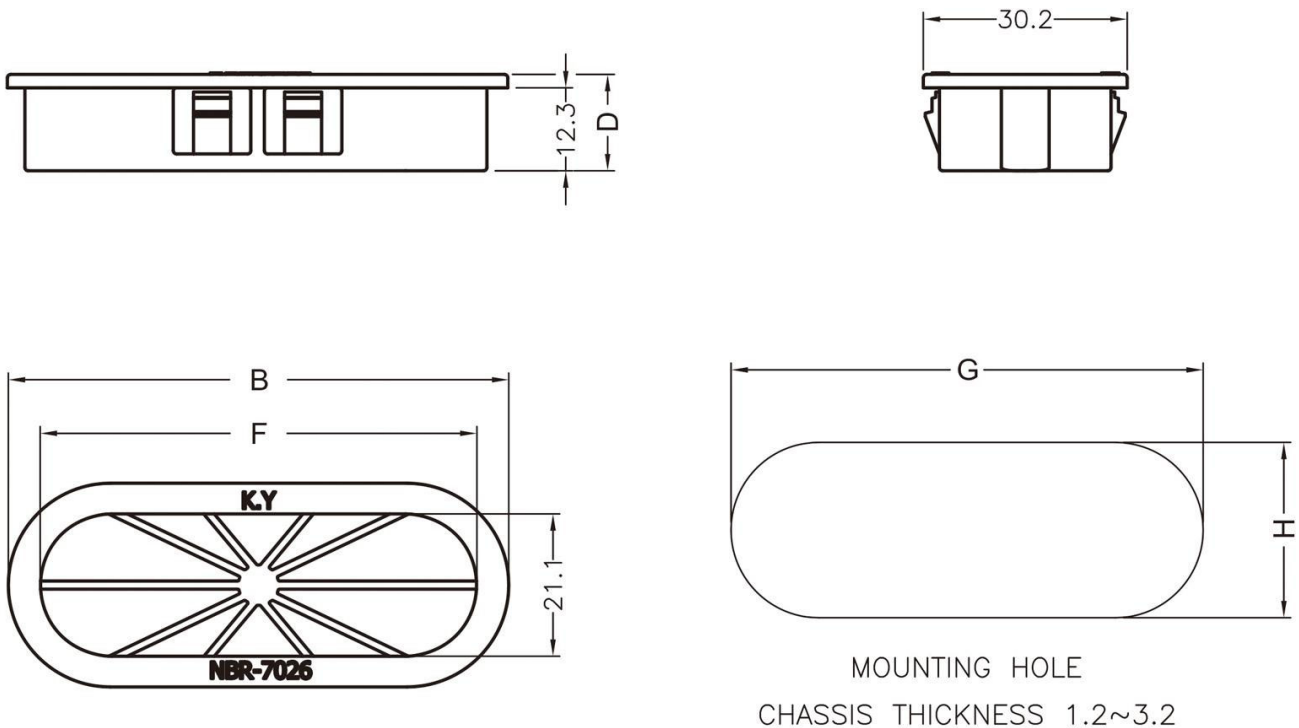

PART NO	B	D	E	F	G	H	PACKAGE
NBK-36	59.2	14.3	1.2~3.2	49.9	55.0	20.0	100

(规格 / 尺寸) 代码说明：

E : 装配板厚

南京诺金电气有限公司

Nanjing Nowking Electric Co., Ltd

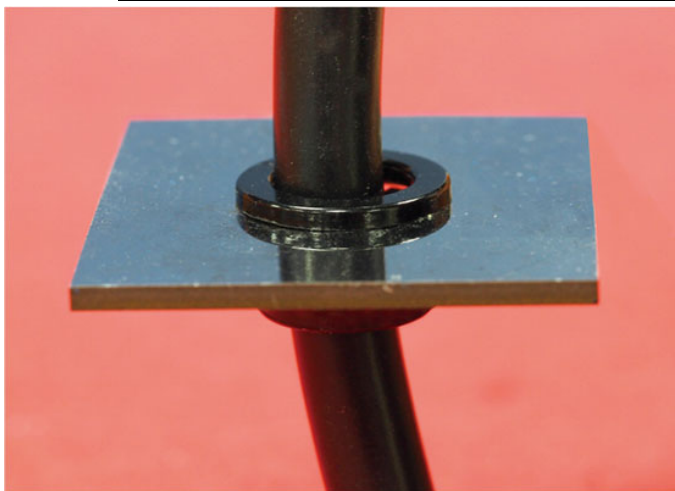

产品名称：护线环

规格型号：NBK-37

- ◆ MATERIAL: NYLON 66(UL)
- ◆ FLAME CLASS: 94V-2, 94V-0
- ◆ COLOR: BLACK, NATURAL
- ◆ UNIT: mm

用途：用于机壳的电线出线口，保护电线不受机壳刮伤，装配容易。

可使用同等材质

NBK-37 结构图

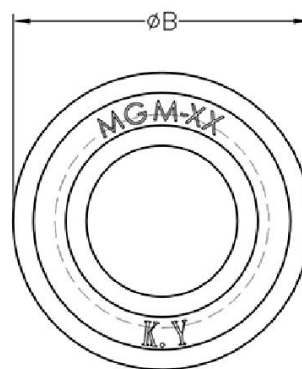
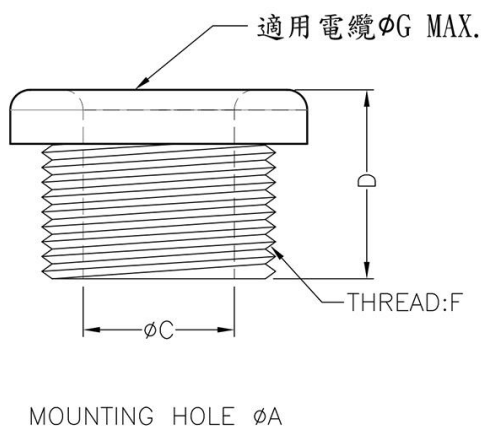

PART NO	A	B	C	D	F	G	H	PACKAGE
NBK-37	ϕ 12.0~ ϕ 12.5	ϕ 18.0	ϕ 8.8	12.0	M12X1.5P	ϕ 8.5	KGB12-07A	500

(规格 / 尺寸) 代码说明：

A：装配孔

G：适用电缆

H：搭配螺帽

南京诺金电气有限公司

Nanjing Nowking Electric Co., Ltd

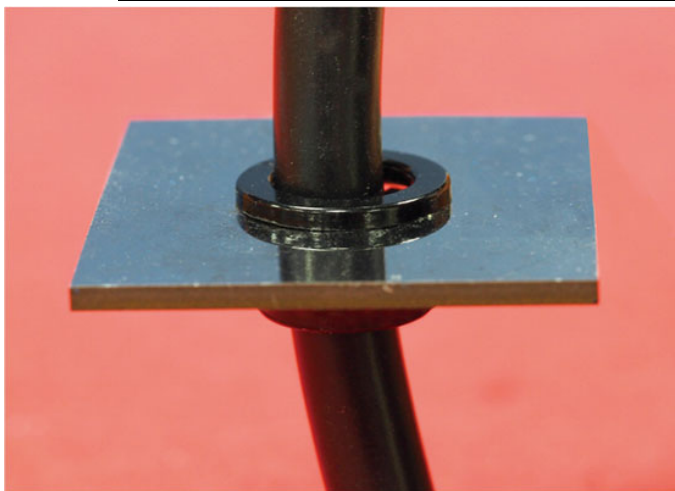

产品名称：护线环

规格型号：NBK-38

- ◆ MATERIAL: NYLON 66(UL)
- ◆ FLAME CLASS: 94V-2, 94V-0
- ◆ COLOR: BLACK, NATURAL
- ◆ UNIT: mm

用途：用于机壳的电线出线口，保护电线不受机壳刮伤，装配容易。

可使用同等材质

NBK-38 结构图

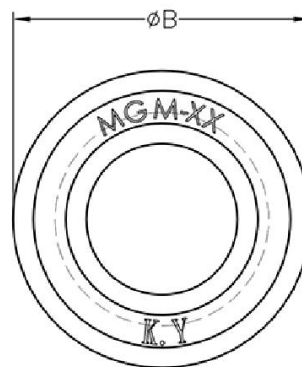
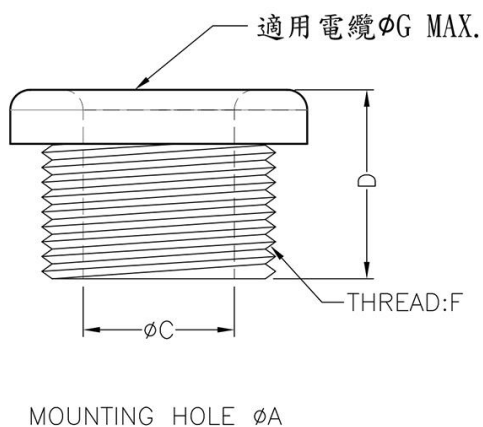

PART NO	A	B	C	D	F	G	H	PACKAGE
NBK-38	ϕ 16.0~ ϕ 16.5	ϕ 21.7	ϕ 11.2	13.5	M16X1.5P	ϕ 11.0	KGB16-10A	500

(规格 / 尺寸) 代码说明：

- A：装配孔
- G：适用电缆
- H：搭配螺帽

南京诺金电气有限公司

Nanjing Nowking Electric Co., Ltd

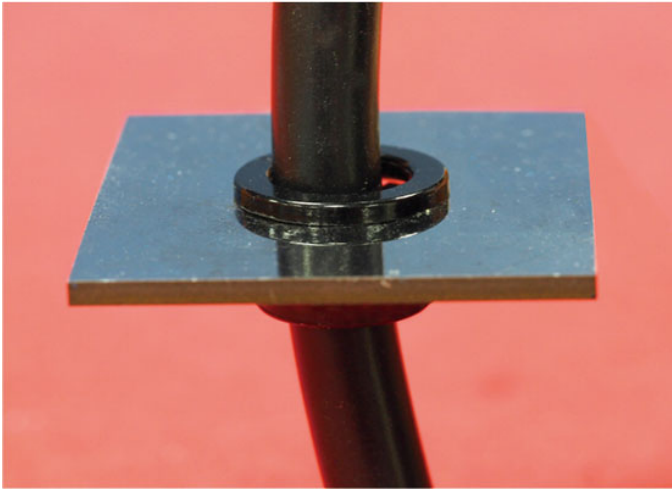

产品名称：护线环

规格型号：NBK-39

- ◆ MATERIAL: NYLON 66(UL)
- ◆ FLAME CLASS: 94V-2, 94V-0
- ◆ COLOR: BLACK, NATURAL
- ◆ UNIT: mm

用途：用于机壳的电线出线口，保护电线不受机壳刮伤，装配容易。

可使用同等材质

NBK-39 结构图

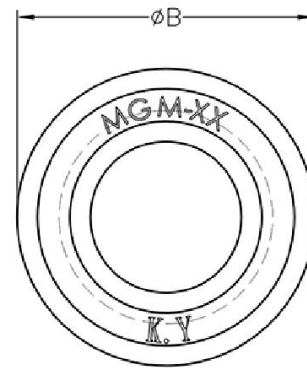
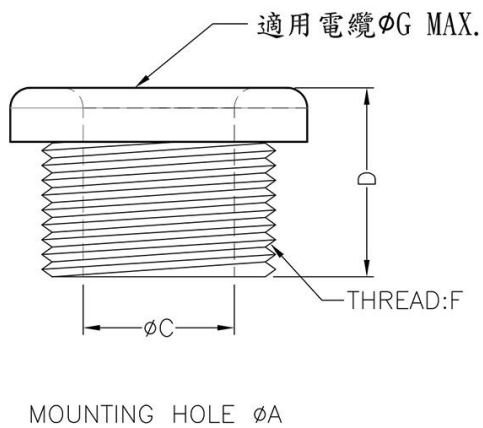

PART NO	A	B	C	D	F	G	H	PACKAGE
NBK-39	Ø20.0~Ø20.5	Ø26.8	Ø15.2	13.5	M20X1.5P	Ø15.0	KGB20-14A	100

(规格 / 尺寸) 代码说明：

- A：装配孔
- G：适用电缆
- H：搭配螺帽

南京诺金电气有限公司

Nanjing Nowking Electric Co., Ltd

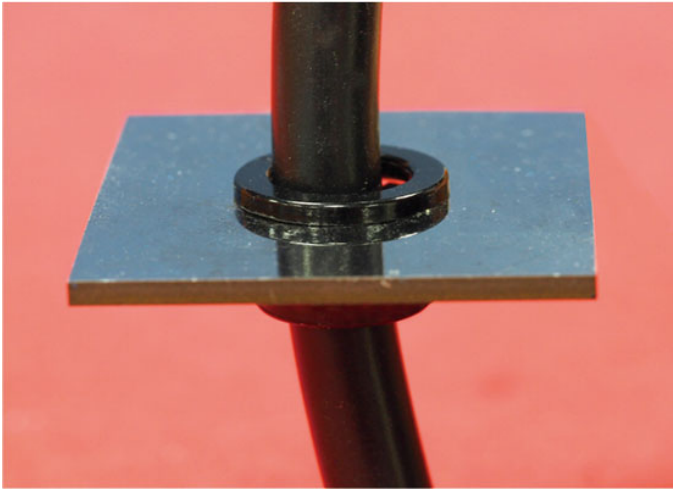

产品名称：护线环

规格型号：NBK-40

- ◆ MATERIAL: NYLON 66(UL)
- ◆ FLAME CLASS: 94V-2, 94V-0
- ◆ COLOR: BLACK, NATURAL
- ◆ UNIT: mm

用途：用于机壳的电线出线口，保护电线不受机壳刮伤，装配容易。

可使用同等材质

NBK-40 结构图

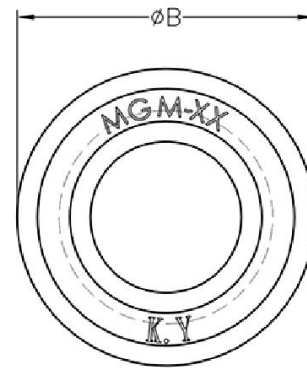
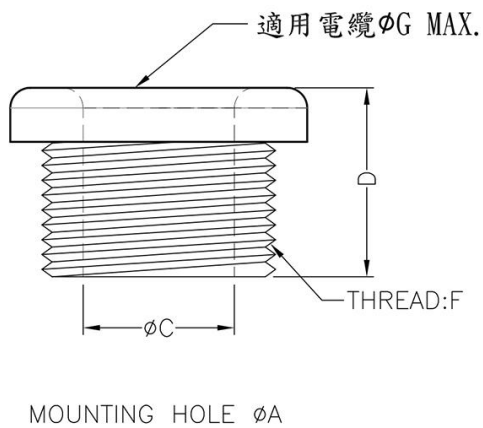

PART NO	A	B	C	D	F	G	H	PACKAGE
NBK-40	Ø25.0~Ø25.5	Ø33.0	Ø19.2	14.0	M25X1.5P	Ø19.0	KGB25-16A	100

(规格 / 尺寸) 代码说明：

- A：装配孔
- G：适用电缆
- H：搭配螺帽

南京诺金电气有限公司

Nanjing Nowking Electric Co., Ltd

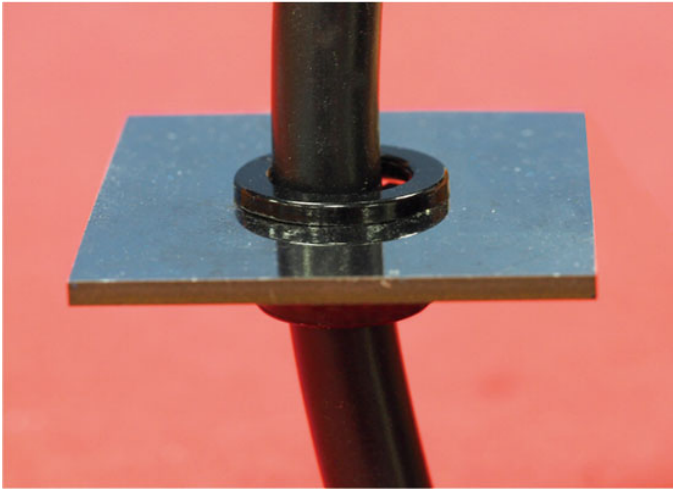

产品名称：护线环

规格型号：NBK-41

- ◆ MATERIAL: NYLON 66(UL)
- ◆ FLAME CLASS: 94V-2, 94V-0
- ◆ COLOR: BLACK, NATURAL
- ◆ UNIT: mm

用途：用于机壳的电线出线口，保护电线不受机壳刮伤，装配容易。

可使用同等材质

NBK-41 结构图

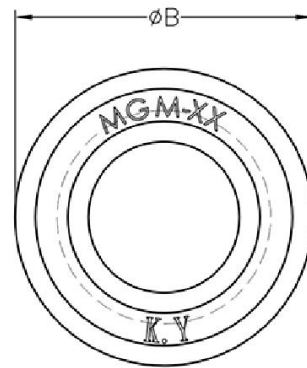
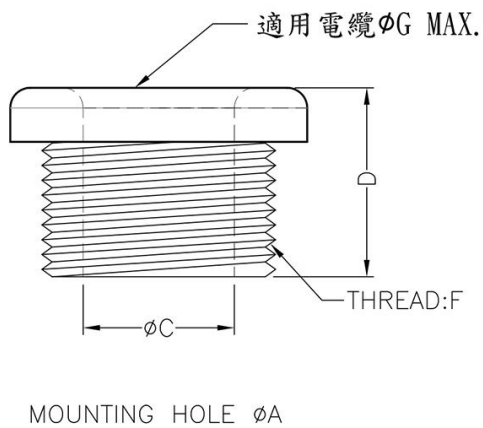

PART NO	A	B	C	D	F	G	H	PACKAGE
NBK-41	ϕ 32.0~ ϕ 32.5	ϕ 42.0	ϕ 26.2	19.0	M32X1.5P	ϕ 26.0	KGB32-25A	100

(规格 / 尺寸) 代码说明：

- A：装配孔
- G：适用电缆
- H：搭配螺帽

南京诺金电气有限公司

Nanjing Nowking Electric Co., Ltd

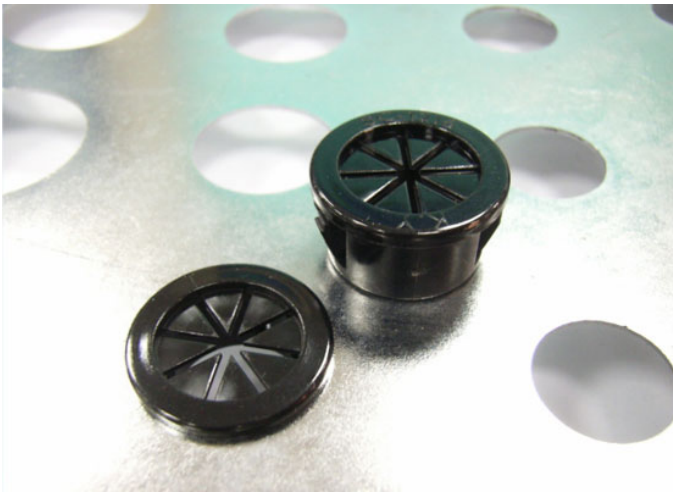

产品名称: 护线环

规格型号: NBK-42

- ◆ MATERIAL: NYLON 66(UL)
- ◆ FLAME CLASS: 94V-2, 94V-0
- ◆ COLOR: BLACK
- ◆ UNIT: mm

用途: 用于机壳的电线出线口, 保护电线不受机壳刮伤, 装配容易。

NBK-42 结构图

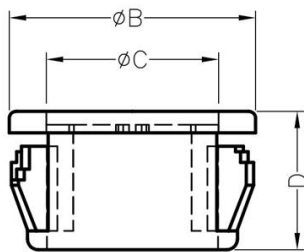

THICKNESS E

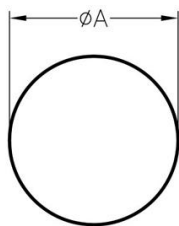
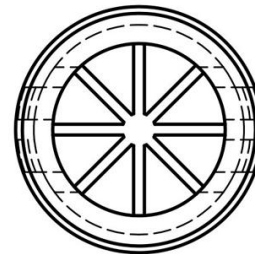

MOUNTING HOLE

PART NO	A	B	C	D	E	PACKAGE
NBK-42	15.9	18.3	12.8	10.3	3.2 MAX	1000

(规格 / 尺寸) 代码说明:

E : 装配板厚